

GB Operating instructions

X3 Mini Gimbal

No. 10009RC



INTENDED USE

i Please download the latest version of the operating instructions from our website at www.rclogger.com. Navigate to the product page and open the "Downloads" tab. Click on "Operating instructions" to start the download.

✓ Make this product available to third parties only together with its operating instructions.

The X3 Mini Gimbal attaches to the NovaX 350 quadcopter and can hold camera models such as GoPro® HERO4 Black/Silver, GoPro® HERO3+, GoPro® HERO3, Yi camera (Xiaomi) or cameras of similar size. The gimbal is supplied with power by the NovaX 350 flight battery and controlled via transmitter/receiver. It is solely intended for private use in the model making area and not to be used for commercial applications.

Any use other than the one described can damage the device. Moreover, this involves dangers such as short circuit, fire and electric shock, etc. Observe the safety information under all circumstances! The product must not become damp or wet.

For safety and approval purposes (CE), you must not rebuild and/or modify this product. If you use the product for purposes other than those described above, the product may be damaged. In addition, improper use can cause hazards such as short circuiting, fire, electric shock etc. Read the instructions carefully and keep them.

DELIVERY CONTENT

- > Gimbal with mounting plate
- > Adapter plate
- > USB adapter
- > Bracket
- > 4 x Standoffs
- > 2 x V-brackets (for mounting on other aircraft)
- > 2 x Knurled bolts
- > 2 x Cable covers
- > 4 x Nuts
- > 4 x Shrink tubes
- > 12 x Rubber dampers (6 x red, 6 x black)
- > 1 x Foam
- > Operating instructions

SAFETY INSTRUCTIONS

⚠ Read the operating instructions carefully and especially observe the safety information. If you do not follow the safety instructions and information on proper handling in this manual, we assume no liability for any resulting personal injury or damage to property. Such cases will invalidate the warranty/guarantee.

✓ Consult the »NovaX 350 manual for instructions on how to attach, connect and operate accessories. Mind the max. takeoff weight.

- > The device is not a toy. Keep it out of the reach of children and pets.
- > Do not leave packaging material lying around carelessly. These may become dangerous playing material for children.
- > Protect the product from extreme temperatures, direct sunlight, strong jolts, high humidity, moisture, flammable gases, vapours and solvents.
- > Do not use the product in rain.
- > Do not place the product under any mechanical stress.
- > If it is no longer possible to operate the product safely, take it out of operation and protect it from any accidental use. Safe operation can no longer be guaranteed if the product:
 - » is visibly damaged,
 - » is no longer working properly,
 - » has been stored for extended periods in poor ambient conditions or
 - » has been subjected to any serious transport-related stresses.
- > Please handle the product carefully. Jolts, impacts or a fall even from a low height can damage the product.
- > Also observe the safety and operating instructions of any other devices which are connected to the product.

INSTALLATION

1. We recommend you watch the following supporting videos before you start with the installation:
 - » <https://vimeo.com/album/3529115>
2. Study the installation diagrams on page 2.
3. Remove legs, camera platform and receiver (see fig. 1).
4. Loosen the screws that hold the center piece in place and remove them (see fig. 2).
5. Remove the vibration isolators (see fig. 2).
6. Install standoffs (see fig. 3). Apply little Loctite® Blue to the screw threads.
7. Install center piece and receiver again (see fig. 4).
8. Attach the rubber dampers to the adapter plate and secure it on the standoffs with the provided nuts (see fig. 5, step 1). Tighten the nuts with moderate force (fig. 5, step 2).
9. Remove protective foil from foam and stick the foam on centre of gimbal platform. Remove the upper protective foil. (see fig. 5, step 3). **Note:** This step is optional. The foam helps to absorb vibrations.
10. Attach the camera mounting plate with gimbal to the rubber dampers (see fig. 5, step 4).
11. It is recommended to secure adapter plate and mounting plate by means of cable ties on two corners (diagonally across from each other). Insert the cable tie through the hole in adapter plate, rubber damper and mounting plate. For easy removal do not fully tighten the cable ties and ensure that they do not inhibit damper travel (see fig. 5, step 5).
12. Install a camera (see fig. 5, step 6).
13. Secure the camera with bracket and knurled bolts (see fig. 5, step 7).
14. Secure any loose cables with cable ties.
15. Installation is complete (see fig. 6).

ELECTRICAL CONNECTION

i The current NovaX 350 firmware versions only allow for controlling pitch. Future firmware versions will offer additional controls.

✓ Refer to the NovaX 350 manual if needed.

⚠ Install a camera before establishing the power supply!

Notes: if you use another receiver/transmitter set than the **RC Logger 89102RC**, it may be capable of supporting all of the gimbal's functions. Besides axis control, the gimbal allows for real-time analog video signal transmission. A socket for a video cable is built-in at the rear of the gimbal.

Wire the gimbal as follows:

1. Study the chapter "Operation" and the wiring diagram (fig. 7).
2. Remove the NovaX 350 canopy.
3. Wire the gimbal as shown in the wiring diagram (fig. 7).
 - » If you use the **RC Logger 89102RC** receiver and transmitter set, connect the cable with **brown and black wire (to switch between modes)** OR the cable with **blue wire (to control pitch)** to the **GIMBAL_X** header on the flight control board. The connector with white wire currently has no function.
4. Preferably, wrap the wires with the supplied cable covers and shrink tubes to protect them.
5. Connect the power cable to the JSTXH connector on the flight battery to supply it with power. **Install a camera before you supply power to the gimbal!**

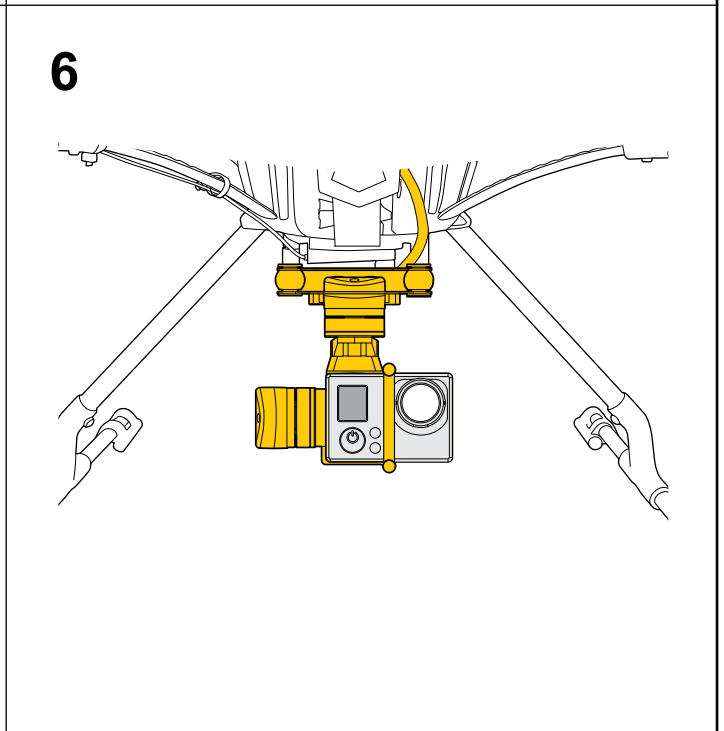
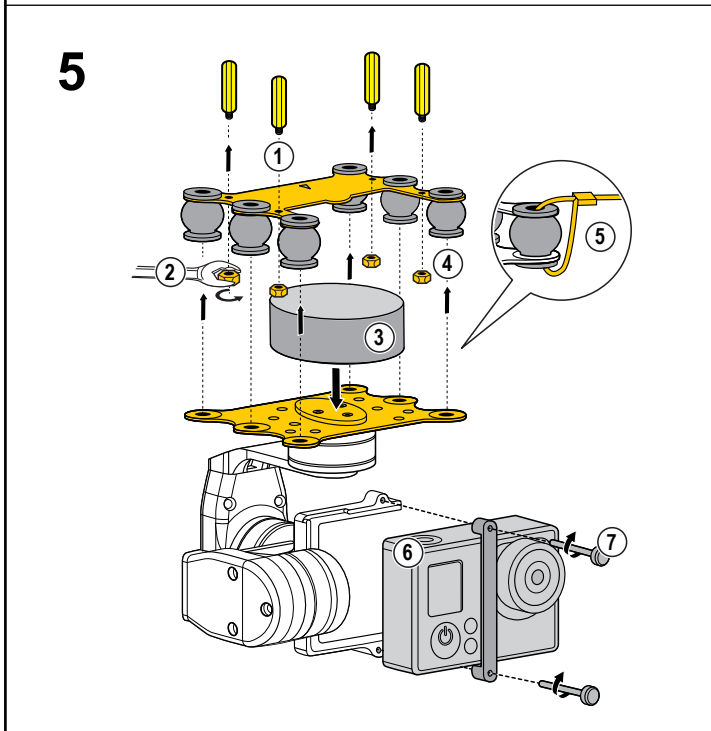
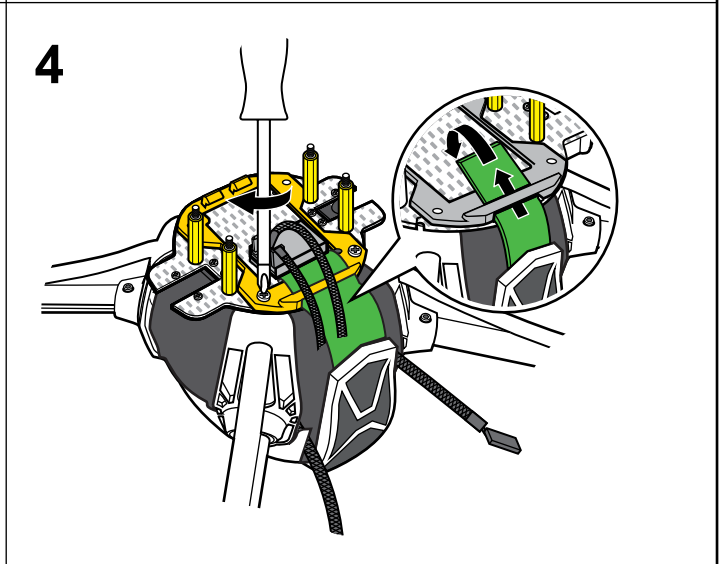
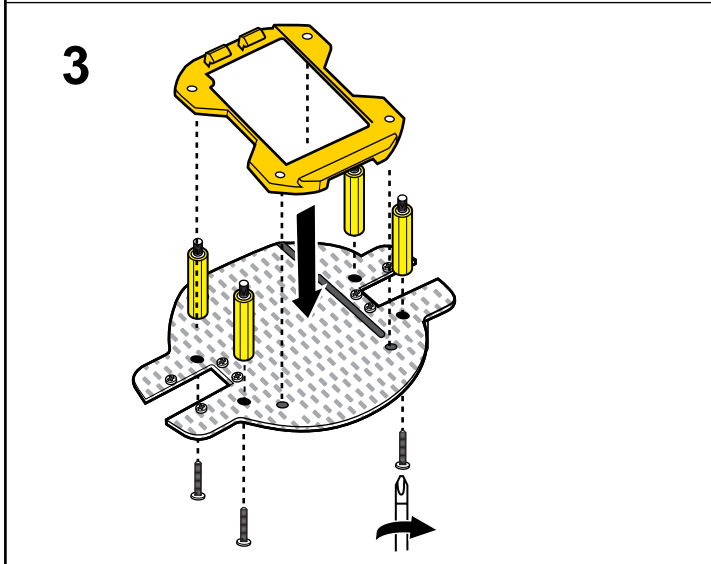
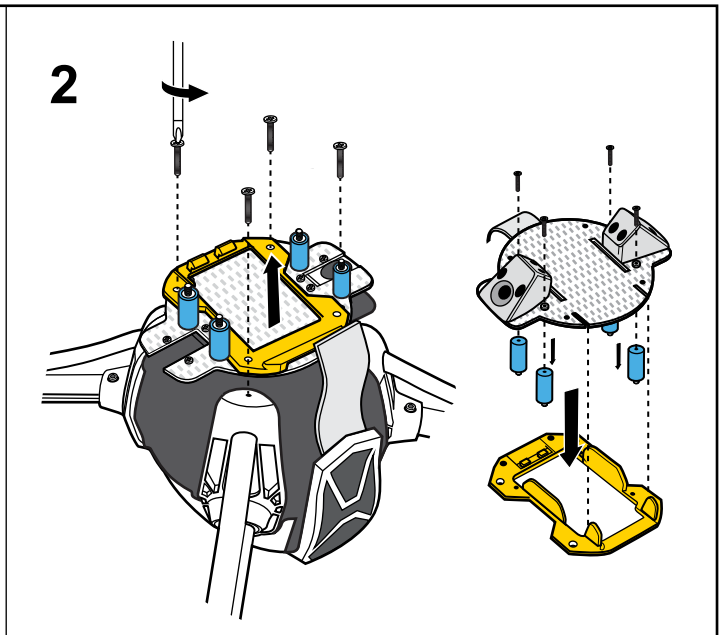
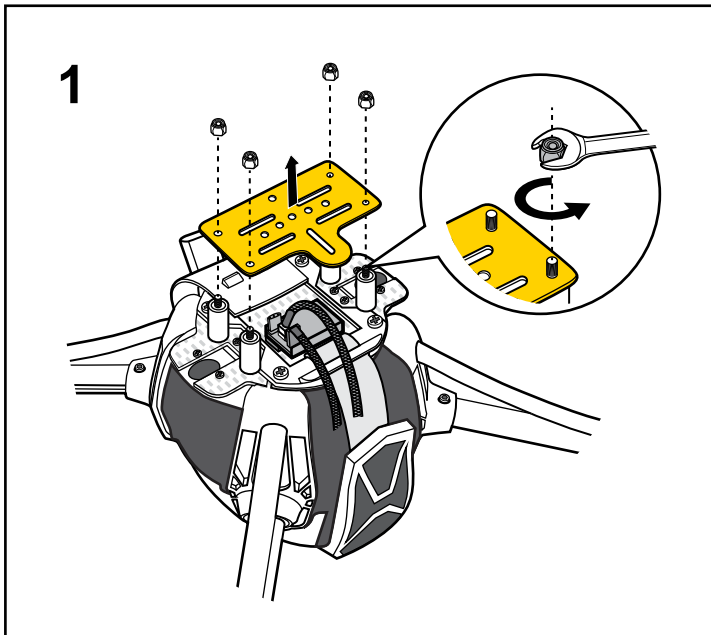

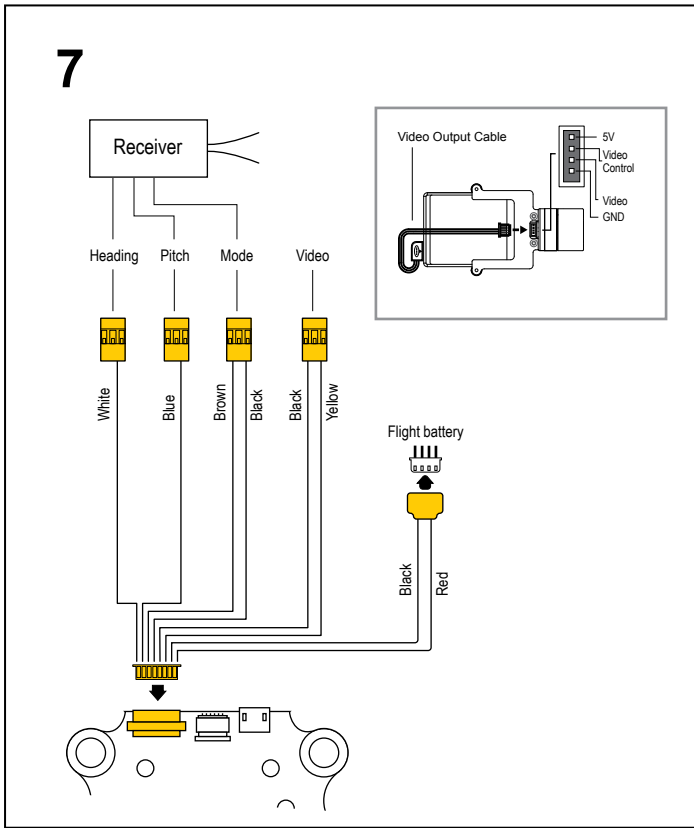

FIRMWARE UPGRADE

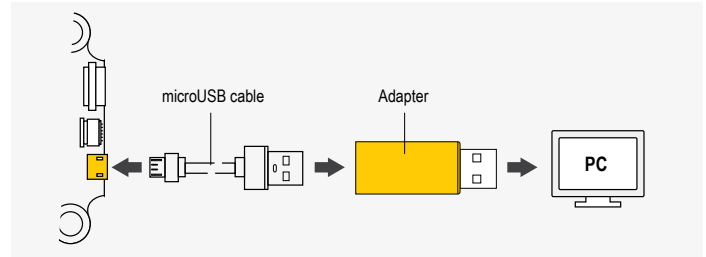

Upgrade the gimbal firmware as follows:

1. Download the firmware upgrade tool from www.rclogger.com. Follow the instructions given in the tool.
2. Download the latest firmware from www.rclogger.com.
3. Connect the gimbal to your computer as shown in the above image. Make sure to use the supplied USB adapter.
4. Refer to the instructions given in the firmware upgrade tool to upgrade the gimbal to the latest firmware version.

DISPOSAL



In order to preserve, protect and improve the quality of environment, protect human health and utilise natural resources prudently and rationally, the user should return unserviceable product to relevant facilities in accordance with statutory regulations. The crossed-out wheeled bin indicates the product needs to be disposed separately and not as municipal waste.

Consequently you comply with your legal obligations and contribute to environmental protection!

PRODUCT SUPPORT

Visit <http://www.rclogger.com/support> or call +852 2559 2662 for product support. Additionally visit our Online Ticket System at <http://support.rclogger.com> for any RC Logger inquiry.

OPERATION

Modes

The gimbal features different modes. Pitch and heading are controllable via receiver.

Mode	Meaning	
Heading follow	Pitch controlled via receiver. Camera pitch and roll angles remain constant; heading follows nose.	<p>1 Pitch, 2 Roll, 3 Heading</p>
Heading and pitch follow	Roll remains constant. Heading follows nose position. Pitch follows elevation of aircraft.	
Heading lock	Heading and pitch controllable via receiver. Heading, pitch and roll are locked at one position.	

Initialization

The gimbal is or needs to be initialized in the following situations:

- > when powering it on for the first time.
- > when powering it on and pitch or roll angle is not parallel to horizon line.
- > when in heading lock mode and heading angle does not lock (unstable).

Initialize the gimbal after mounting it to the NoxaX 350 as follows:

1. Keep the gimbal motionless.
2. Establish power supply.
3. Do not move the gimbal and it initializes automatically.
4. Upon completion, pitch and roll angles are parallel to the horizon line and heading follow mode is activated.

CLEANING AND CARE

- > The product does not require any maintenance, do not disassemble it. Maintenance or repairs may be carried out by a professional only.
- > Before cleaning, always disconnect it from the power supply.
- > Clean the exterior of the product using a clean, soft, dry cloth only. You can easily remove dust using a clean, soft brush or a vacuum cleaner.
- > Do not use any aggressive cleaning agents or chemical solutions as these may damage the housing causing discoloration and/or malfunction.

TECHNICAL DATA



Update the NovaX 350 firmware to at least version FW v1.5 in order for you to be able to use the manual and automated calibration features of the gimbal.

Item	Min.	Standard	Max.	Remarks
Operating voltage	7 V	8.4 V	17 V	
Static Attitude Tracking Accuracy	0.01	0.02	0.05	Gimbal in static mode
Motion Attitude Tracking Accuracy	0.1	0.2	0.5	Motor overload <2G
Overload Current Protection	800 mA			
Pitch Angle	-90° (Down)	0° (Horiz.)	+45° (Up)	
Roll Angle	-45°	0° (Horiz.)	+45°	
Heading Angle	-120°		+135°	
Pitch Following Rate	2°/sec		25°/sec	
Heading Following Rate	3°/sec		75°/sec	
Weight	162 g			Without camera

These operating instructions are published by CEI Conrad Electronic International (HK) Limited, 18th Floor, Tower 2, Nina Tower, No. 8 Yeung Uk Road, Tsuen Wan, New Territories, Hong Kong. All rights including translation reserved. Reproduction by any method, e.g. photocopy, microfilming, or the capture in electronic data processing systems require the prior written approval by the editor. Reprinting, also in part, is prohibited. The operating instructions reflect the current technical specifications at time of print.